

POWER SOURCE



**5 YEAR
WARRANTY**

30W

Phase Cut Dimmable LED Driver with PWM Output

Features of the PDV-30 Series:



Constant
Voltage PWM
Output



IP20 Design
For Indoor
Installation



AC Input Range:
200-240VAC



Cooling by
Free Air
Convection



Protections:
• Short Circuit
• Over Load
• Over Current
• Over Temperature



Factory
Fitted Flex
and Plug



Class II
Power Supply



Compatible
with Most
Leading and
Trailing Edge
Dimmers



Australian
Approvals

CE     IP20 SELV

Specification

Model		PDV-30-12	PDV-30-24
Output	DC voltage	12V	24V
	Voltage tolerance	±0.5V (see Note 2.)	
	Rated current	2.5A	1.25A
	Rated power	30W	
Input	Voltage range	200-240VAC	
	Frequency range	47-63HZ	
	Power factor	PF ≥ 0.97/200VAC PF ≥ 0.97/230VAC PF ≥ 0.97/240VAC (Full loading)	
	Full load efficiency (Typ.)	79%	79%
	AC current (Max.)	0.22A	0.22A
	Leakage current	<0.50mA	
	Inrush current	(Typ.): Cold Start 30A (twidth = 90us measured at 50% Ipeak) at 230 VAC	
	MAX. No. of drivers on 16A Circuit breaker	6 units (circuit breaker of type B) / 6 units (circuit breaker of type C) at 230VAC	
Protection	Short circuit	Shut down o/p voltage, re-power on to recover after fault condition is removed	
	Over loading (Note 4.)	≤ 120% shut down o/p voltage, re-power on to recover	
	Over current	≤ 1.2 *Iout	
	Over temperature	100°C ± 10°C shut down o/p voltage, re-power on to recover	
Environment	Working TEMP.	-40-+70°C (refer to de-rating curve)	
	Working humidity	20-90%RH, non-condensing	
	Storage TEMP., humidity	-40-+80°C, 10-95%RH	
	TEMP. coefficient	±0.03%/°C (0-50°C)	
Safety & EMC	Vibration	10-500Hz, 2G 10min./1 cycle, period for 72min, each along X, Y, Z axes	
	Safety standards	EN61347-1 EN61347-2-13	
	Withstand voltage	I/P-O/P: 3.75KVAC	
	Isolation resistance	I/P-O/P: 100MΩ/500VDC/25°C/70%RH	
Others	EMC emissions (Note 3.)	EN55015, EN61000-3-2,3 (≥60%loading)	
	Net. weight	0.21KG	
	Size	155*54*20mm (L*W*H)	
Notes	Packing	160*60*23mm for inner box; 350*240*130mm for carton 40PCS/CTN	
	<ol style="list-style-type: none"> All parameters NOT specially mentioned are measured at 230VAC input at rated load and 25°C of ambient temperature. Tolerance: Includes set up tolerance, line regulation and load regulation. The power supply is considered as a component that is operated in combination with final equipment. EMC performance could be affected by the complete installation. Original equipment manufacturers may need to conduct additional EMC testing and certification on the final equipment. Loading range from 10% to 100%. Specifications are subject to change without prior notice. Contact your supplier to confirm any critical parameters. 		

Mechanical Specification

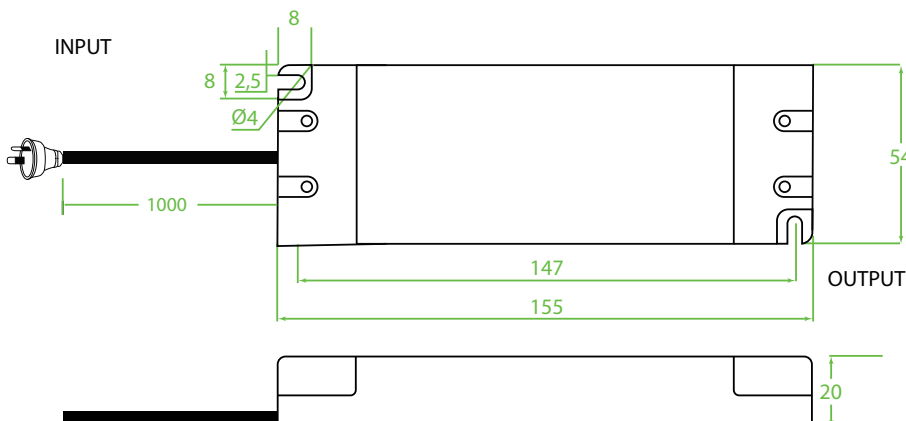

- Connect LED to LED driver via screw terminals under removable cover. Positive (LED+), Negative (LED-).
- Suggested output wire diameter: 0.5-2.5mm².
- Incorrect wiring could result in damage to the power supply, which is not covered by the warranty.
- Contact your supplier with specific input, or output configuration requests.

Dimming Operation

Dimming Operation

- Dimming is with installing a leading edge, or trailing edge dimmer across the AC input.
- Compatible with most leading and trailing edge dimmers. Australian compatibility chart available on request.
- It is recommended that a dimmer, with a power rating three times higher than that of the rated output of the LED driver is used.

Connection Diagram

- Single Driver Connection Diagram.

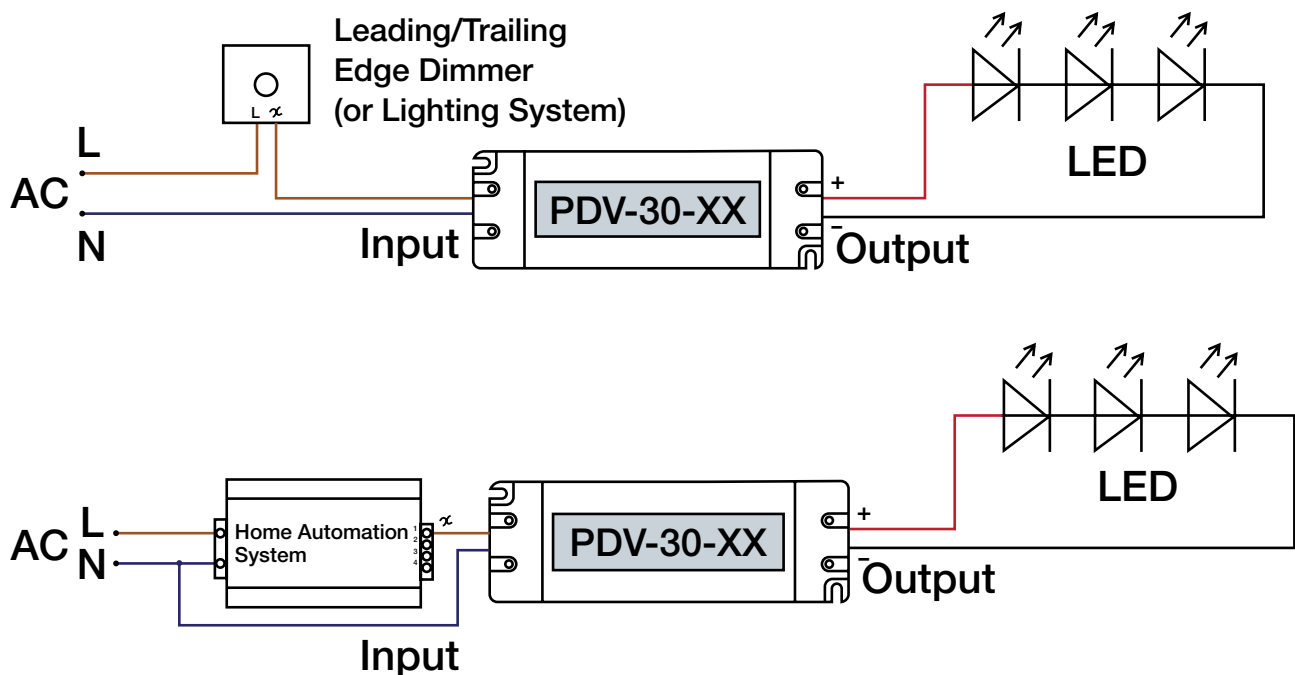

Connection Diagram

- Multiple Drivers Connection Diagram.

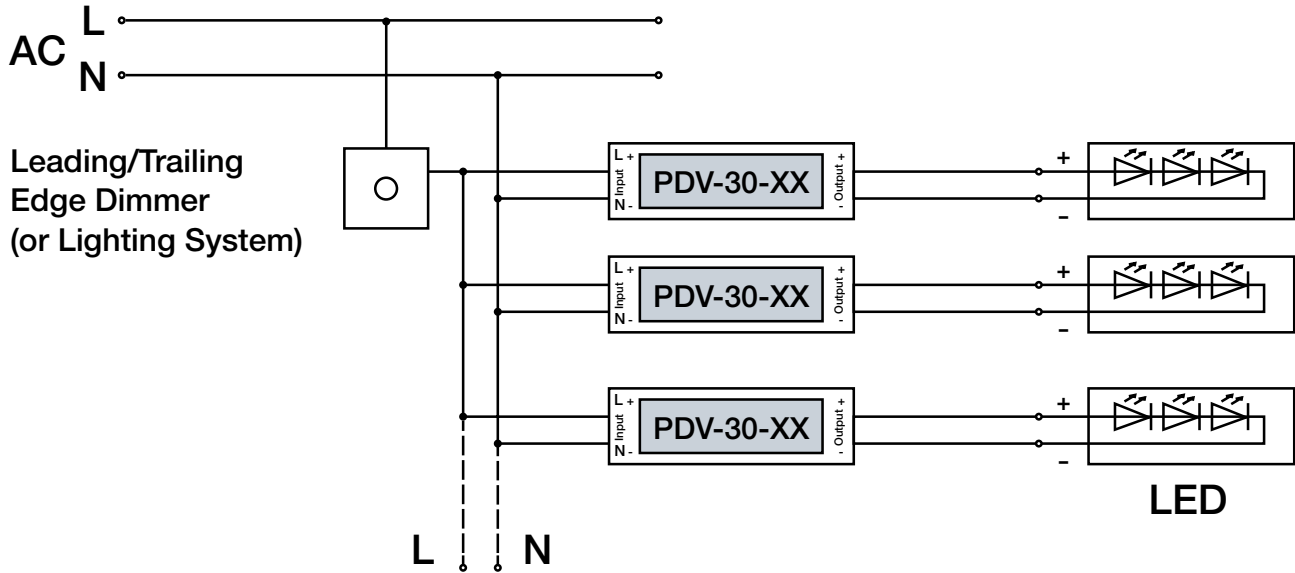

De-rating Curve

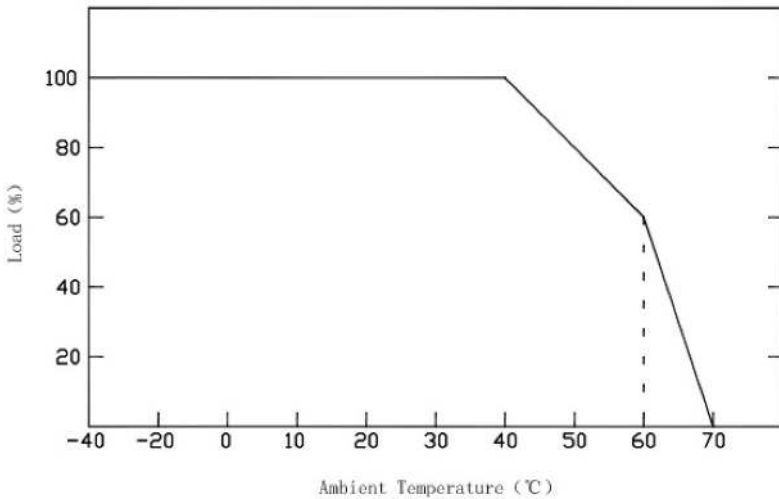

- If being used in higher ambient temperatures, ensure the load on the LED driver is de-rated in accordance with this chart. Failure to do so could lead to a failure, which is not covered by the warranty



Instruction:

- 1) This LED driver should be installed by a qualified electrician.
- 2) Please make sure the LED driver is installed with adequate ventilation around it to allow for heat dissipation.
- 3) Ensure that all wiring is correct before testing in order to avoid damage to the LED driver, or the LEDs.